



MUNSCH
Plastic Pumps for Aggressive Media

Chemical pumps

Vertical cantilever pump Type TPC

In PP/PE-UHMW/PVDF

- ▶ vertical setting depths up to 1800 mm
- ▶ pump capacity up to 600 m³/h
- ▶ total differential head up to 65 m
- ▶ tolerant of solids
- ▶ dry run-proof

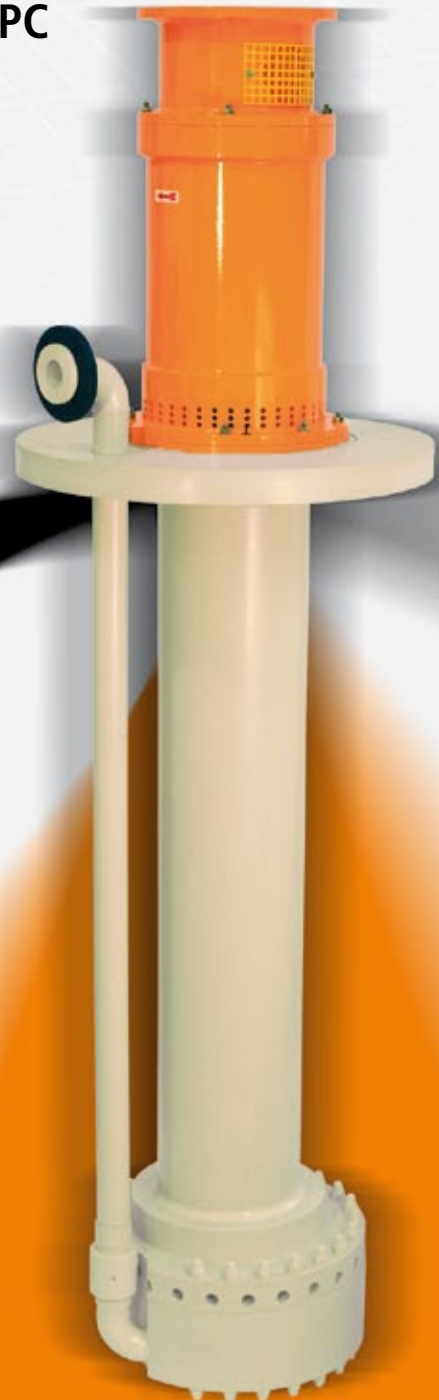

Vertical cantilever pump TPC

► Applications

Dry run-proof Type TPC vertical cantilever pumps are the solution of choice whenever it comes to pumping solids-laden acids, alkalis or chemically contaminated effluents or when there is a risk of prolonged dry running. Typical applications include the metal finishing industry, steel and stainless steel pickling lines, evaporation and regeneration units, flue gas cleaning systems downstream of waste incinerators as well as exhaust air cleaning and scrubber effluent treatment.

► Construction

Vertical centrifugal pump with volute casing and single-entry, single-stage radial impeller; without bottom bearing; the shaft bearing is located outside the path of the fluid pumped.

► Materials

Part designation	Standard material range		
	PP	PE-UHMW	PVDF
Pump casing	PP	PE-UHMW	PVDF
Casing cover	PP	PE-UHMW	PVDF
Pump shaft	St		
Impeller	PP ¹⁾	PE-UHMW ¹⁾	PVDF ¹⁾
Bearing lantern	GGG		
Secondary seals ²⁾	FPM		
Shaft protection sleeve	PP	PP	PVDF
Column pipe	PP	PP	PVDF
Suspension pipe	PP	PP	PVDF
Casing flange	PP	PP	PVDF
Sole plate	PP	PP	PP

1) Material combinations possible

2) Alternatives (depending on fluid pumped): EPDM or Viton-PTFE-coated

PP	Polypropylen
PE-UHMW	Ultrahigh-molecular polyethylene
PVDF	Polyvinylidene fluoride
FPM	Fluoroelastomer
EPDM	Ethylene propylene diene elastomer
PTFE	Polytetrafluoroethylene

► Performance data for 50/60 Hz operation

Pump capacity [Q] up to	600 m ³ /h
Total differential head [H] up to	65 m
Motor rating [P] up to	45 kW
Vertical setting depths [I] up to	1800 mm

► Shaft seal

Double V-ring seal

► Flange connection

Standard design with stub end and backing flange to DIN, optionally to ANSI or JIS.

► Drive

Three-phase A.C. motor, design V1 with canopy to IEC, BS or NEMA; type of protection, flameproof enclosure and motor voltage to customer specifications.

► Coating

Paint system for metallic pump components:

Base coat: epoxy resin primer;

Top coat: PU-based finish,

RAL 2003, pastel orange. Total dry film thickness

130–150 µm. Special coatings available on request.

► Maximum allowable service pressures and temperatures

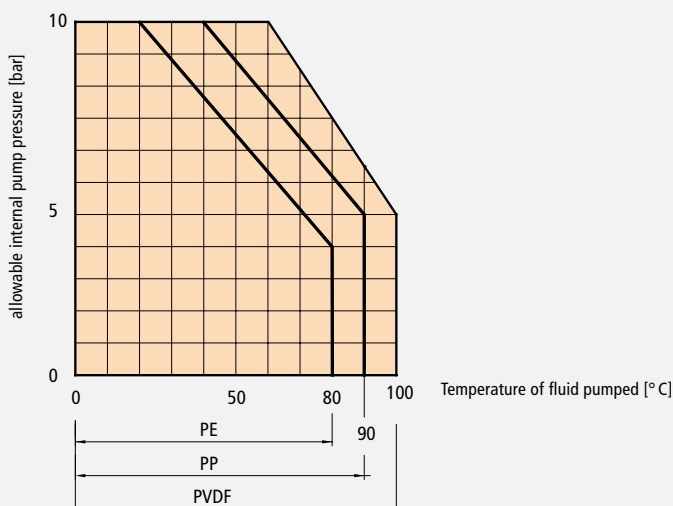

► Arrangement

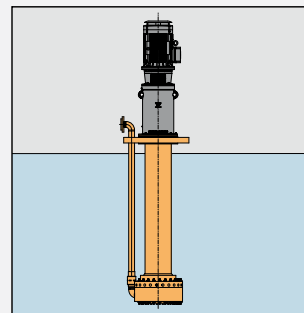

3.1) With flange and elbow, wet-end installation

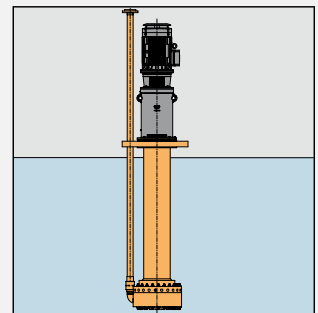

3.2) With top flange, wet-end installation

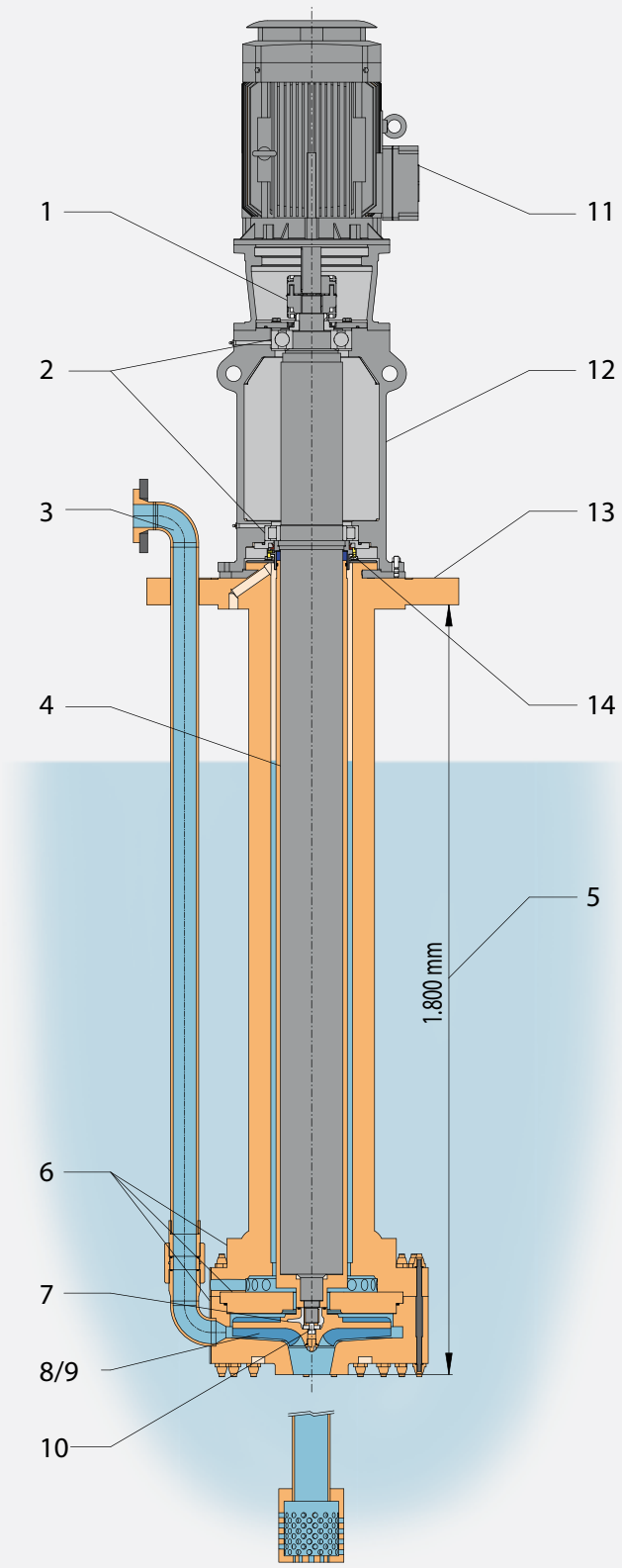

► Design features

- 1 Flexible coupling connecting motor shaft to pump shaft.
- 2 Anti-friction bearing installed in lantern. Shaft bearing can accommodate high loads even under part load conditions.
- 3 Column pipe with 90° elbow and flange; connection by a suitable pipe union allows the column pipe and/or the discharge flange to be rotated to virtually any position (Fig. 3.1).
Option: column pipe with flange or design to customer's specification (Fig. 3.2)
- 4 Steel shaft with solid plastic protection sleeve
- 5 Standard setting depths 1000 mm and 1800 mm
- 6 Volute casing, casing cover and suspension pipe made of solid plastics; with ample abrasion allowance; maximum reliability when handling corrosives and abrasives.
- 7 Solid impeller hub ensures plastics stability even at high temperatures.
- 8 Impeller: closed design (Fig. 8.1); semi-open (Fig. 8.2) or vortex (Fig. 8.3) impellers can be provided on request.

Pump size	Maximum allowable particle size [mm]		
	Impeller design		
	semi-open	closed	Vortex impeller
65-40-200	8	6	–
80-50-250	10	8	–
80-50-315	8	8	13
100-65-315	12	10	–
125-100-250	–	18	–
200-150-250	–	18	–

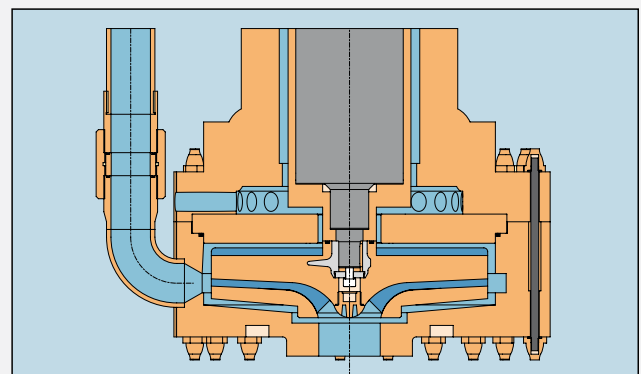

8.1) Closed impeller

Accessories/Option: Suction strainer/suction pipe

- 9 Optimum hydraulic design using the latest numerical methods ensures:
 - good suction behaviour due to low NPSH requirements
 - minimum mechanical vibration of components
 - long service life of anti-friction bearings
 - minimized running noise.
- 10 Impeller is positively locked to the shaft for reverse rotation protection..
- 11 Standard motor, design V1 with canopy
- 12 Low external height above, slim construction below the sole plate
- 13 Circular or rectangular sole plate; special sole plate geometries and sole plates with supporting flange available on request.
- 14 Double V-ring seal reliably protects the bearings from solids, liquids and vapours.
Option: Radial lip sealing

► **Accessories/Options**

- Suction strainer
- Suction pipe up to a length of 1600 mm
- Suction strainer and suction pipe
- Motor overload switch (not shown)

► **Explosion protection to EU Directive 94/9/EG (option)**

Additional constructional measures allow the use of the TPC in explosion hazard areas. The pump meets the requirements of EU Directive No. 94/9/EG.

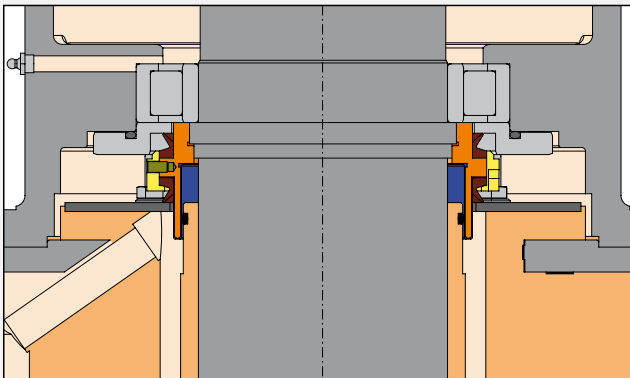

14) Double V-ring seal

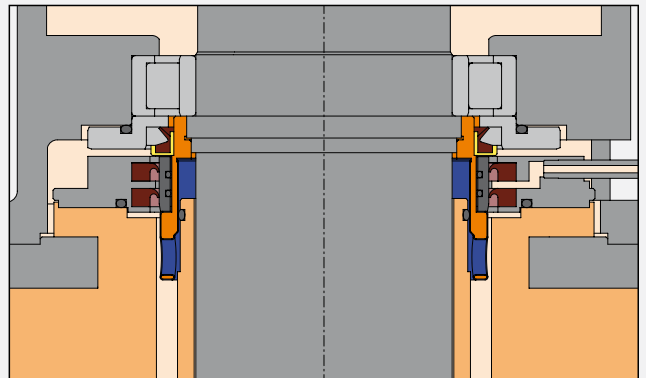

14.2) Radial lip sealing

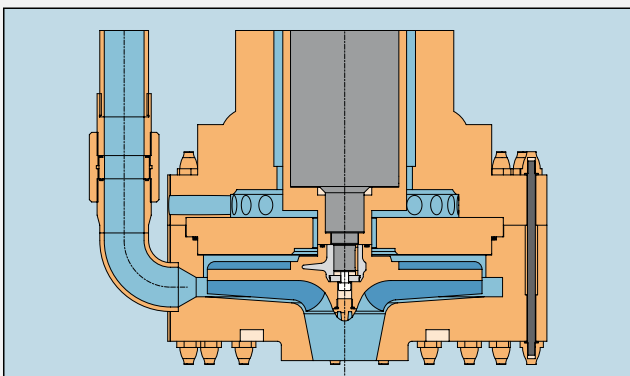

8.2) Semi-open impeller

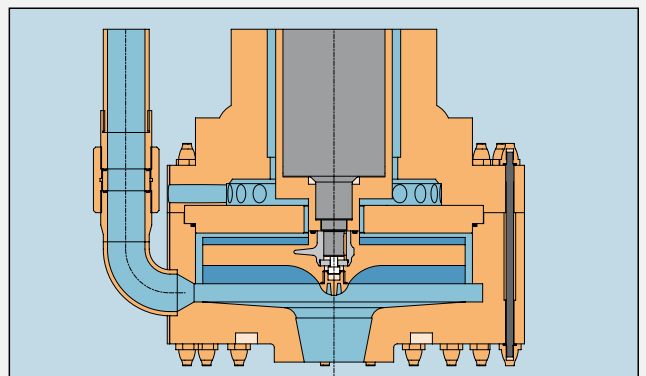

8.3) Vortex impeller

► Performance characteristic charts

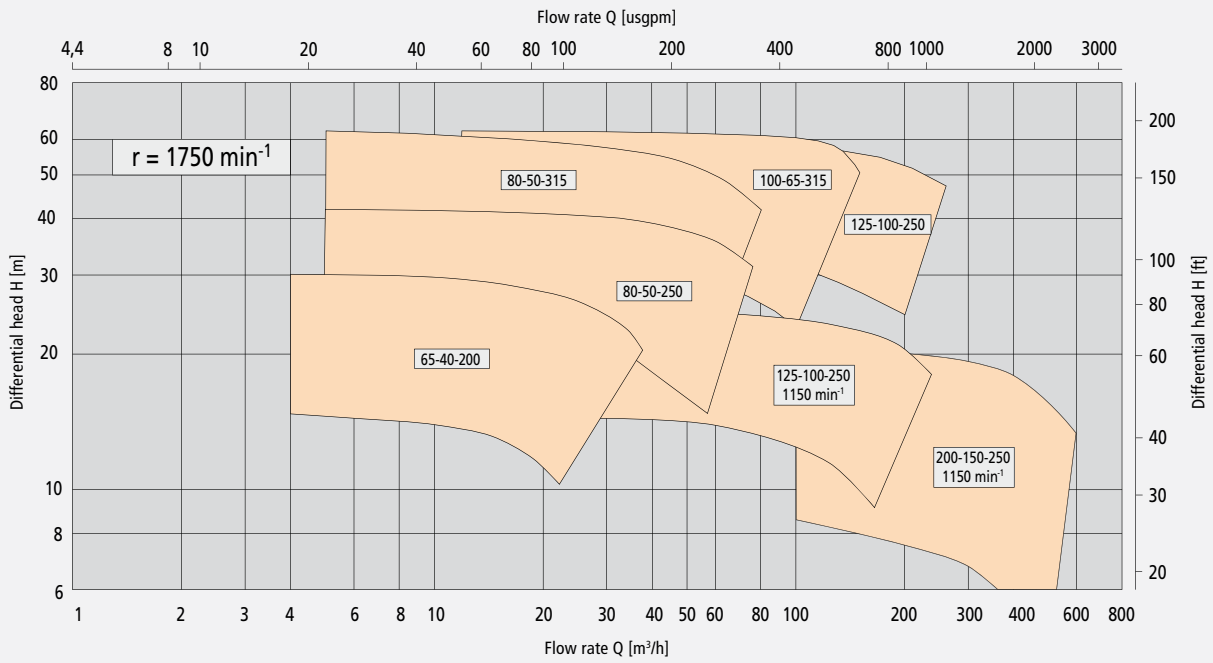
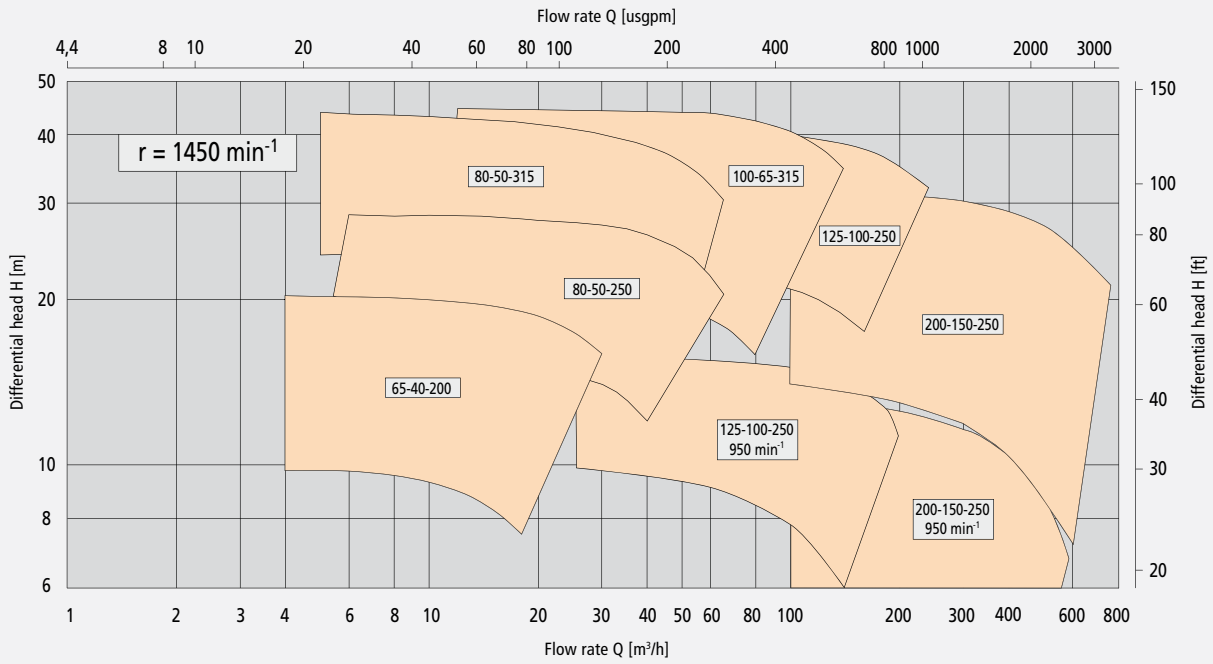

Vertical cantilever pump TPC

► Dimensions – Standard design

Pump size	DNd	DNs	a	ØC	D	E	E2	G	K	LK	p	t
65-40-200	40	65	6	540	370	225	20	778	450	508	12,5	65
80-50-250	40	65	6	540	370	225	20	778	450	508	12,5	65
80-50-315	50	80	10	700	520	285	20	808	595	668	12,5	65
100-65-315	65	100	10	700	520	285	20	808	595	668	12,5	65
125-100-250	100	125	10	760	520	340	50	854	670	728	12,5	65

- A = 1800 or 1000 (Standard)
- Other setting depths on request

Pump size	DNd	a2	d	d2	d4	k
65-40-200	40	4	150	18	88	110
80-50-250	50	4	165	18	102	125
80-50-315	50	4	165	18	102	125
100-65-315	65	4	185	18	122	145
125-100-250	100	8	220	18	158	180

- Flange connection to DIN 2501, PN 16

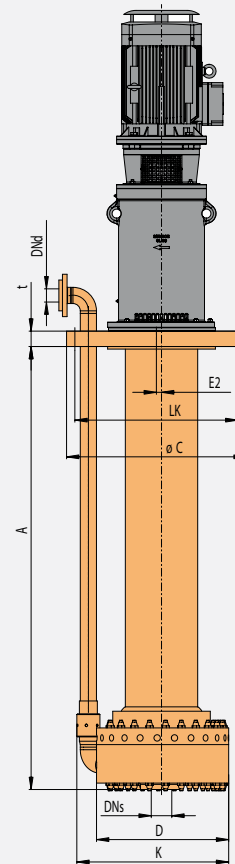
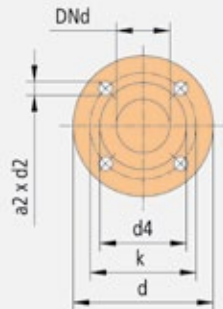

► Sole plate

The standard pump comes with a circular (1) or rectangular (2) sole plate; sole plates with supporting flange (3) and special designs can be provided on request.

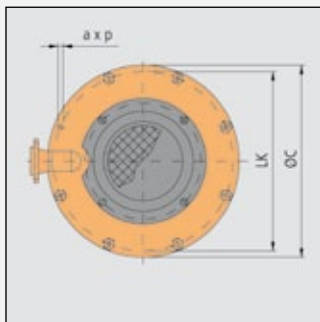

1) Circular sole plate

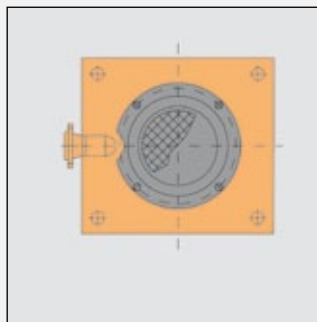

2) Rectangular sole plate

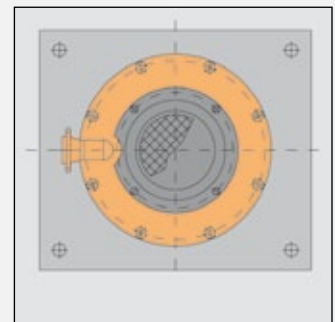

3) Circular sole plate with supporting flange

MUNSCH Chemie-Pumpen GmbH

Im Staudchen · D-56235 Ransbach-Baumbach
P.O. Box 1 42 · D-56221 Ransbach-Baumbach
Germany

Phone: +49 (0) 2623-8 98-90

Fax: +49 (0) 2623-8 98-95

Internet: <http://www.munsch.de>

E-Mail: munsch@munsch.de